

Morris Chair

A faithful reproduction of a classic.

I don't care what they say about dogs, Morris chairs are a man's best friend. The reclining back, wide arms and expansive seat create the perfect place to watch TV, read the Sunday paper or simply contemplate the finer qualities of a well-crafted beer.

For the last 10 years, I've spent every weekend planted in the original version of this chair, which was built by the Shop of the Crafters in Cincinnati, Ohio, during the heyday of the Arts & Crafts movement. The Shop of the Crafters was founded by German-American businessman Oscar Onken (1858-1948), who ran a successful framing company until he entered the furniture business in 1902, according to



1 Make the mortises in the legs before you shape the curve near the bottom or make cutouts on the top.

Kenneth R. Trapp's history of the company.

Unlike many furniture-makers of the day, Onken didn't want to merely copy the Stickleys of the world. Onken produced an unusual line of Arts & Crafts furniture that was influenced more by German and Hungarian designs than the straight-lined Stickley pieces of the day. In all honesty, a few of Onken's pieces were kind of ugly. Most, however, had a refinement and lightness that rivaled some of the best work of the day.

This Morris chair is an almost exact replica of the one produced by Onken and his company. It differs in only two ways. One, the original chair was constructed using dowels at the major joints. After almost 100 years of use, the front and back rail came loose. This chair is built using pegged mortise-and-tenon joints. Second, I made one change to the chair frame so that furniture historians of the future will know instantly that this not an original piece. I did this to prevent people from passing off these reproductions as originals.

Though this project might look daunting to you, it can be completed by beginners who have just a few projects under their belt. There are only a few principles to learn here: mortising, tenoning and routing with a plywood template. Plus, I'll share with you exactly how I achieved this finish, which has been something we've been working at for several years.

How to Save Money on Lumber

Begin by choosing the right quartersawn white oak for this project. It requires about 10 board feet of 8/4 and 30 board feet of 4/4 lumber. Quartered white oak can be expensive, from \$6 to \$12 a board foot. If you live in the Midwest, or will pass near east-central Indiana on your vacation, I recommend you check out Frank Miller Lumber Co. in Union City, Ind. (765-964-7705). The company is a huge supplier of quartersawn oak. As a result, prices are reasonable, about \$4 to \$6 a board foot. Once you buy your lumber, save the pieces with the most ray flake for the arms, legs, front and sides. To save money, use flat-sawn oak for the seat and the adjustable back.

4



When pattern-routing the curve on the legs, make sure you have the work firmly clamped in place. I have the pattern and leg wedged between two pieces of oak (the pattern is on the underside of the leg). Then the leg itself is clamped to the table. You also could perform this operation on a router table with a starting pin for pattern-routing.

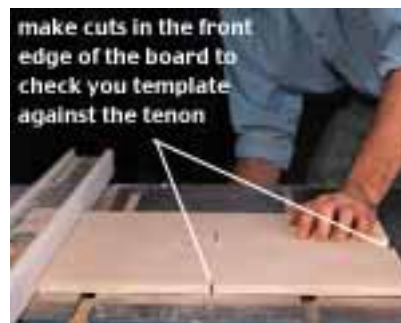

3 To make a template for the mortises in the arms and the cutouts on the side slats, position your plywood over your table saw and raise the blade into the ply. Move the fence over and repeat. Then turn the pattern 90 degrees and repeat for the other edges of the pattern. Note that I made cuts in the front of the pattern to help me size the pattern to the tenons.



Be sure to make a full-size mock-up of the legs and sides to determine the angle you need to cut on the bottom of the legs.

Mortises: Machine or No Machine?

First cut all your pieces to size according to the Schedule of Materials and begin laying out the locations of your mortises. The rule of thumb is that your mortises should be one half the thickness of your tenon's stock. When your stock is 3/4" thick, your mortises and tenons should be 3/8" thick. That means the tenons for the beefy back rail should be thicker (7/16") and those for the side slats should be thinner (1/4").

Also remember that except for the tenons on the legs and slats, all the tenons are 3/4" long. To ensure your tenons don't bottom out in your mortises, it's always a good idea to make your mortises about 1/16" deeper than your tenons are long.

After you mark the locations of all the mortises, it's time cut them. There are 38 mortises in this project.. You'd be nuts to do these all by hand. Use this project as an excuse to purchase a hollow chisel mortising machine (about \$250) or a mortising attachment for your drill press (about \$70). If you can't swing the cash, I'd make plywood templates and cut the mortises with a router and a pattern bit. Making plywood templates is something covered later in the story.

One more thing: don't cut the mortises in the arms or the arm buildups until the chair frame is assembled. You'll cut these with a router and a pattern bit after the chair frame is assembled.

Tenons With a Dado Stack

Once you get your mortises cut, make tenons that fit snugly into the mortises. You can use a tenoning jig or the fence on your table saw, or you can use a router. I prefer to use a dado stack and my miter gauge.

While your dado stack is in your saw, cut the groove in the back piece that holds the seat frame. See the drawing for the location of this groove.

Once you cut your tenons, prepare to assemble the drop-in seat and the adjustable back. To save yourself some grief, sand the edges of the rails that you



When you determine that angle, use a grease pencil or magic marker to paint the bottom of the legs. I cut the back and front legs simultaneously. Slowly inch your legs in after each cut until the color is all gone.



Peg the tenons that join the front rail to the front legs and the back rail to the back legs. If you've ever pegged tenons before, you know that dowels can be wildly different sizes than they're supposed to be. Here's a trick. If your dowel is a bit undersized, glue it in place and cut it nearly flush to the surface. Then put several drops of thinned glue on the end grain of the dowel. It wicks in the glue, expands and glues up tight. When the glue is dry, cut the dowel flush.



Be sure to make a test arm before you go mortising the real thing. You'll be glad you did.

won't be able to get to after the frames are assembled. Now put glue in all the mortises and clamp up the frames. Set them aside to dry.

Curves and Cutouts

What makes this Morris chair stand out are the curves and cutouts on the legs, arms and slats. Each curve and cutout needs a slightly different strategy.

The large curves on the legs and the small curves on the side slats were cut using a plywood template and a pattern-cutting bit in a router. I made the patterns from 1/2"-thick Baltic birch plywood. Use the drawings to make your own plywood template using a scroll saw, band saw or coping saw. Smooth all your cuts with sandpaper, then try shaping a couple scraps with your template to make sure your pattern produces the right shape. When satisfied, cut the curves to rough shape on your band saw (about 1/16" shy of your finished line) and clean up the cut with a router and pattern bit. Finish shaping the legs with a chisel.

To produce the large cutouts on the front legs, do what Oscar Onken did: cheat a bit. Make the "cutouts" using a dado stack on your table saw, with the legs on edge. Then glue the applied sides to the legs to cover the open end of the cuts. Instant cutout. While you're at it, cut out the notches on the arm pieces for the rod that adjusts the back.

To complete the legs, you need to cut the bottom of all four legs at a 2-degree angle so the chair sits flat on the floor. I recommend you make a full-sized mock up (see the photo above) so you can get the angle exactly right. Cut the angle on a chop saw.

Assembly

Now you're almost ready to assemble the chair frame. You'll need to first miter the tenons slightly where they meet to fit in the mortises using your table saw. Now finish sand everything. I went to 150 grit using my random-orbit sander and hand sanded the whole piece with 180 grit. Yes, it makes a noticeable difference.

Now glue the front rail between the front legs and the back rail between the back

legs. Clamp and allow your glue to dry. Use 1/4" dowels to pin the tenons from the inside of the chair. This strengthens the weakest point of this chair. It's at this joint where the original chair came loose.

Glue the side rails between the front and back legs and you can see your chair take shape.

Learn to Make Square Templates

Now you need to work on the arms. First glue the arm buildup pieces to the front of the arms. Then get ready to cut the mortises on the arms that will hold the tenons on the legs and side slats. A word of advice here. Mock up an arm out of scrap wood and practice on it first.

To make plywood templates for the mortises, you need to make a square hole in the middle of a piece of ply. The best way to do this is by making plunge cuts into your plywood on your table saw. Refer to the photo earlier in the story to see how to do this.

Now cut your mortises. I used a template bit with cutters on the bottom and a guide bearing on top. If you don't have a bit with cutters on the bottom, you can still plunge with a straight bit. Just plunge slowly and wiggle the router a bit as you go. Cut the mortises in two passes.

After you're sure the arms fit on the legs, cut the curve on the front of the arm. Attach the full-size pattern to your arm and cut the shape on a band saw. Clean up the cuts with a stationary belt sander. Now taper the arms with your band saw and clean up the cut with your jointer. Glue the arms and slats in place.

Now shape the back rod that adjusts the seat back angle. Bevel one edge of the rod on your jointer and cut notches on the ends so the rod fits between the arms. Attach the back to the seat frame with a piano hinge. Screw the cleats to the front and back of the frame in the locations shown in the diagram; slip the seat in place.

Finishing

This takes some effort, but it is well worth it. The first step is to dye the chair with an

alcohol-based aniline dye that's reddish. See the supplies list for ordering information. Then apply one coat of boiled linseed oil to the chair. You can get this at any home center store. Wipe off the excess and let it dry overnight. The linseed oil helps seal the wood before your final coloring step and helps bring out the ray flake.

Now wipe on a thin coat of Lilly's warm brown glaze. We live and die by this stuff when finishing Arts & Crafts furniture. We're not aware of a catalog that sells it, but you can visit Lilly's website (at the address in the supplies box) to find a paint store that carries this glaze. Wipe the glaze until you achieve an even tone. Allow it to dry overnight. Finally, apply three coats of a clear finish -- whatever you're comfortable with.**PW**

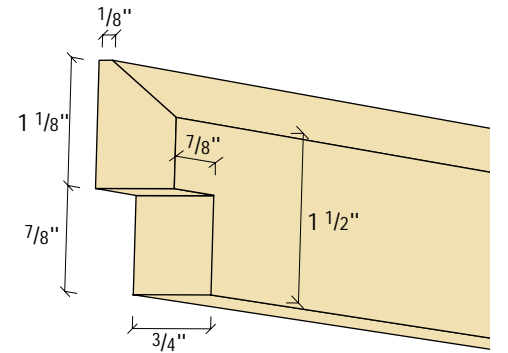
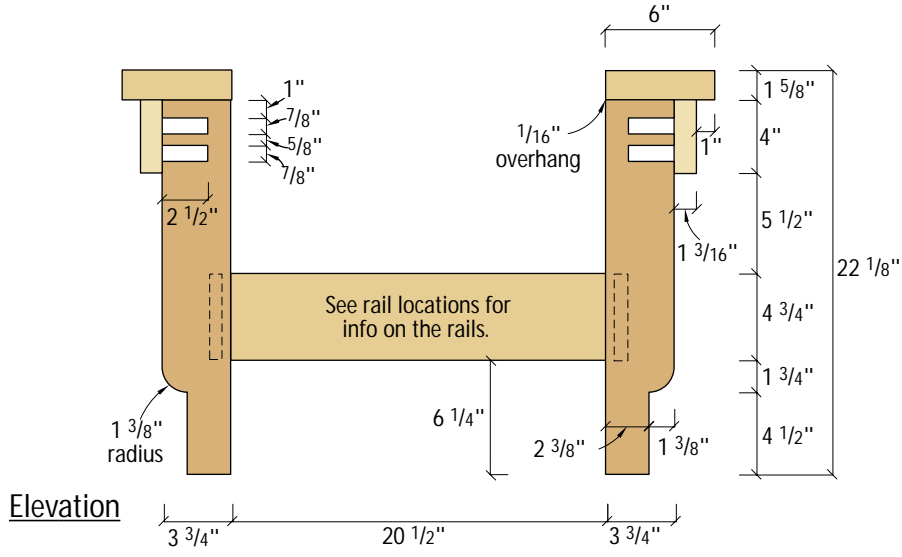
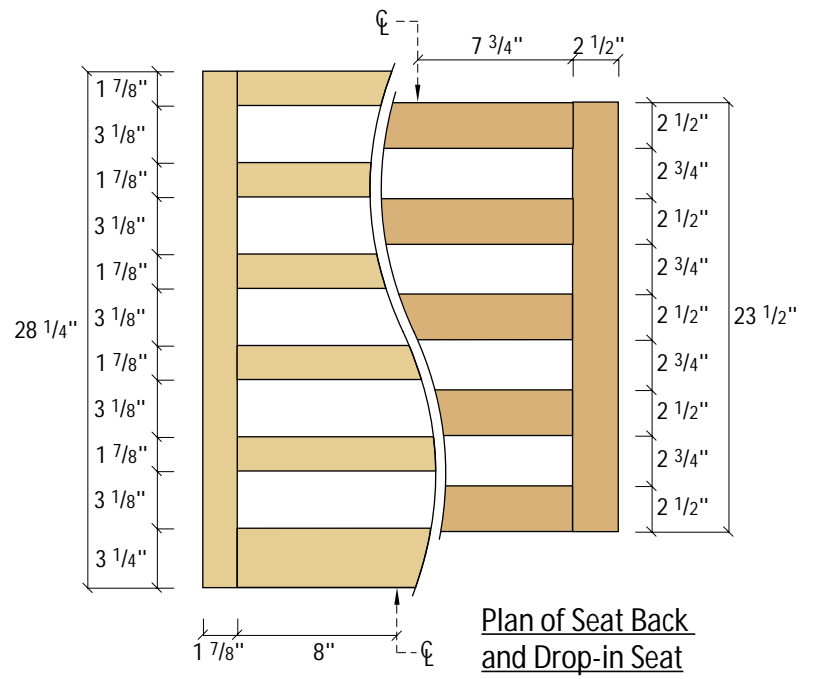
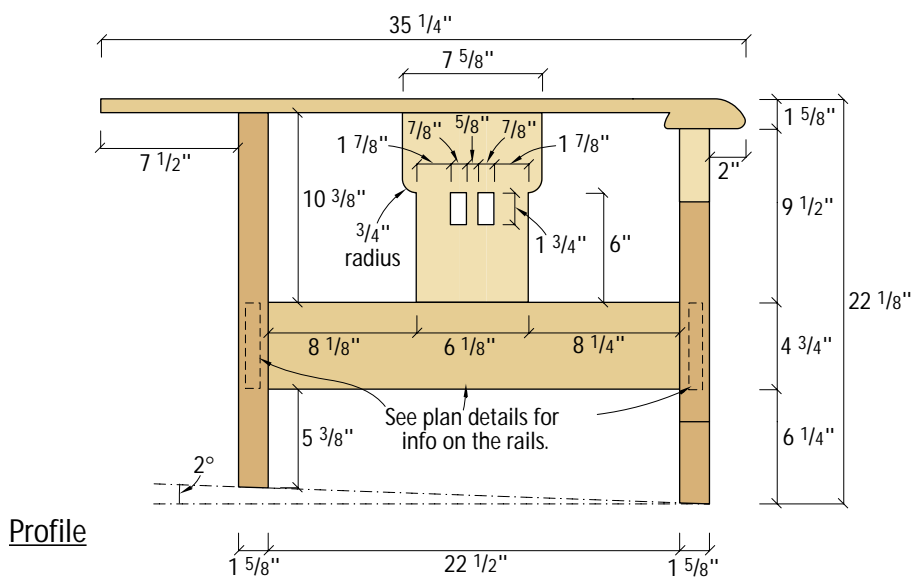

MORRIS CHAIR

NO.	ITEM	DIMENSIONS (INCHES)			NOTES
		T	W	L	
Chair frame					
□ 2	Front legs	1 5/8	3 3/4	21	1/2" TOE
□ 2	Back legs	1 5/8	2 1/4	21	1/2" TOE
□ 2	Applied sides	1 5/8	1 3/16	4	
□ 1	Front rail	3/4	4 3/4	22	3/4" TBE
□ 2	Side rails	3/4	4 3/4	24	3/4" TBE
□ 1	Back rail	7/8	4 3/4	22	3/4" TBE
□ 2	Side slats	1/2	7 5/8	11 3/8	1/2" TBE
□ 2	Arm bldps	7/8	6	4 1/2	
□ 2	Arms	3/4	6	35 1/4	
□ 2	Cleats	3/4	1 7/8	20 1/2	
□ 1	Back rod	3/4	2	23 3/16	
Drop-in seat					
□ 2	Seat stiles	3/4	2 1/2	23 1/2	
□ 5	Seat rails	3/4	2 1/2	17	3/4" TBE
Adjustable back					
□ 2	Back stiles	3/4	1 7/8	28 1/4	
□ 5	Back rails	3/4	1 7/8	17 1/2	3/4" TBE
□ 1	Bottom rail	3/4	3 1/4	17 1/2	3/4" TBE

TOE = tenon on one end • TBE = tenon on both ends

SUPPLIES

Slotted Piano Hinge
 Rockler: 800-279-4441 or rockler.com

J.E. Moser's Golden Amber Maple water-based aniline dye
 Woodworker's Supply:
 800-645-9292 or woodworker.com

Lilly Professional Glaze, choose the color "warm brown"
 Woodfinishingsupplies.com:
 507-280-6515 or woodfinishingsupplies.com

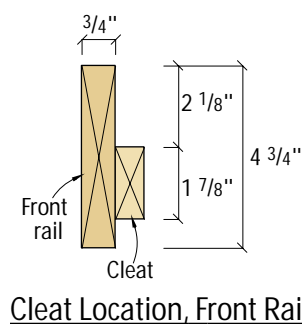
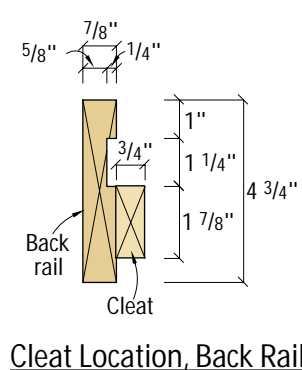
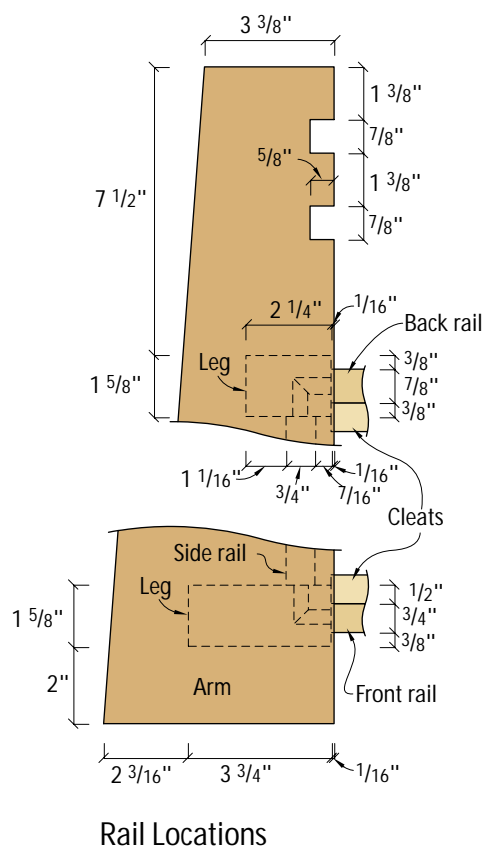
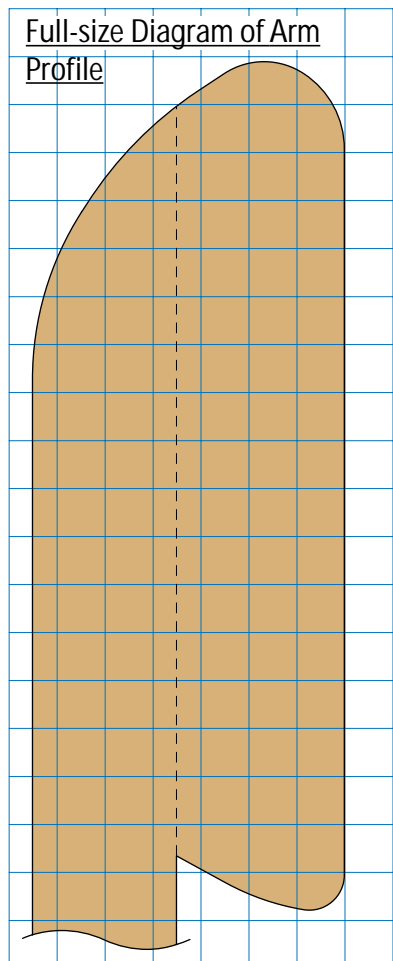

The "X" on the rails and cleats denotes a cross section rather than an end view.